

scan *pack*®

StrapPack

SEMI-AUTOMATIC STRAPPING MACHINE

JK-2



SEMI-AUTOMATIC STRAPPING MACHINE

❑ AUTOMATIC FEED LENGTH

The JK-2 records the length of strap required and feeds exactly the same length automatically for every package. The operator resets the feed length memory and pulls the strap to the length needed. Exactly the same length of strap will be fed on the following cycles.

❑ ADJUSTABLE TABLE HEIGHT

The table height can be easily adjusted from 750mm (30") to 850mm (33 1/2") in 20mm (3/4") increments.

❑ CAPABLE OF SOFT TENSION

The JK-2 has soft tension capability and can strap fragile packages without creating any damage.

❑ EASY STRAP WIDTH CONVERSION

Changing the strap width is very easy. You can use from 5mm to 12 mm (1/2") polypropylene strap. No additional parts are required.

❑ STURDY BODY YET QUIET OPERATION

The JK-2 is solid and durable, manufactured with quality materials, and it is amazingly quiet. The large tabletop provides ample workspace.

❑ EASY MAINTENANCE

The JK-2 has less moving parts than any other strapping machines of its kind, which can save operating cost and simplify the maintenance. In addition, Strapack has developed a new, unique maintenance mode on this machine. When engaged, the JK-2 steps through the strapping cycle one operation at a time. By observing the

operation of the JK-2 in this special mode, it is easy to identify problems and make adjustments. Diagnosing problems has never been easier!

❑ ADVANCED SEALING UNIT DESIGN

The sealing unit slide table design is borrowed from other highly successful Strapack automatic strapping machines. This design means easier maintenance and less wear than the heads on other semi-automatic strapping machines. Thanks to this new design, changing the cutter can be done in minutes. The JK-2 features a new heater design that provides longer life than our previous heaters.

❑ NEWLY DESIGNED REEL BRAKE

The Reel Brake Arm on the JK-2 uses a heavy-duty spring to control the strap coil. This innovative, elegant design provides soft start and stop of the strap coil, increasing the reliability of the JK-2 over other machines in its class. In addition, the parts subject to wear, brake belts and pads, are completely eliminated, another low maintenance feature of the JK-2.

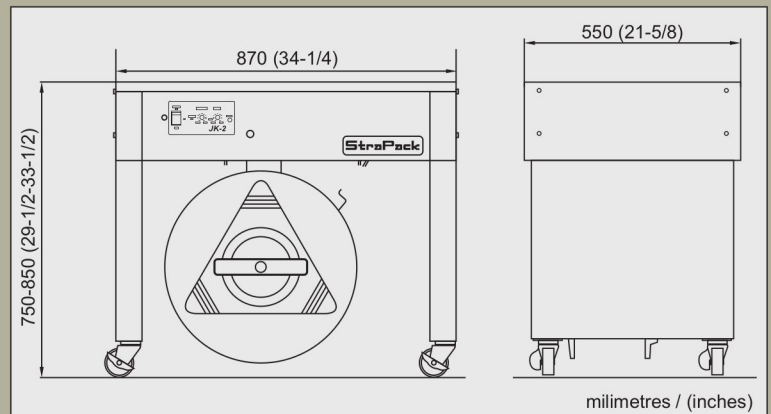

❑ STANDARD SPECIFICATIONS

DIMENSIONS	Width	870 mm	34-1/4 in.
	Height	750 mm - 850 mm	29-1/2 - 33-1/2 in.
	Depth	550 mm	21-5/8 in.
MACHINE WEIGHT		75 kg	167 lbs
TABLE HEIGHT		750, 770, 790, 810, 830, 850 mm	29-1/2, 30-3/8, 31-1/8, 31-7/8, 32-5/8, 33-1/2 in.
PACKAGE SIZE	Min	W90 x H30	W 3-1/2x H1-1/8 in.
	Max	Free	
TENSION		3 - 40 kgf (29.4-392N)	
STRAP WIDTH		5, 6, 9, 12 mm	1/4, 3/8, 1/2 in.
SEALING METHOD		heat sealed	
POWER SUPPLY		100, 110, 120, 220, 230, 240v Single Phase 50/60Hz 0.56 KVA	

Dimensions and specifications are subject to change without notice.

DISTRIBUTED BY:

scan®
pack

SCANPACK Sp.J.

60-175 Poznań, ul. Żonkilkowa 14 • Tel/fax: 061 867 82 81 • Tel: 061 867 73 92
63-500 Ostrzeszów • ul. Św. Mikołaja 25 E • Tel: 062 586 01 10 • Fax: 062 586 01 11

E-mail: poznan@scanpack.pl • ostrzeszow@scanpack.pl

Internet: www.scanpack.pl • www.zgrzewarki.pl • www.tasma.com.pl



STRAPACK CORPORATION
Tokyo, JAPAN